

TANQUES FLEXÍVEIS



TANQUE FLEXÍVEL 25.000L / 6.500Gal US

Laminado de PVC Reforçado
com Tecido de Poliéster 1212

Espessura 1,95mm (DIN EN 22.286)

Peso de 2.380g/m² (DIN EN 22.286)

Adesão de 5Kg / 5cm (DIN 53.357/A)

Resistência a Ruptura (DIN 53.354)
Longitudinal 890Kg / 5cm
Transversal 840Kg / 5cm

Alongamento a Ruptura (DIN 53.354)
Transversal / Longitudinal de 25%

Resistência ao Rasgo (DIN 53.363)
Longitudinal 85Kg
Transversal 80Kg

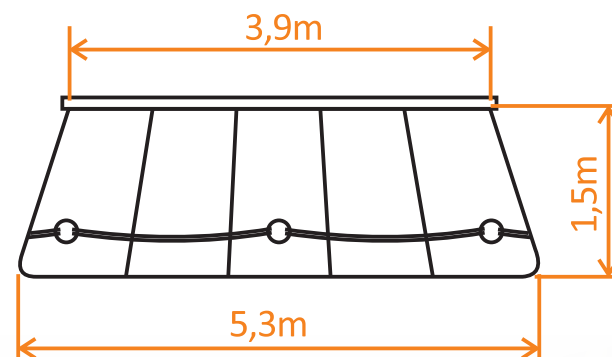

TANQUE FLEXÍVEL 50.000L / 13.000Gal US

Laminado de PVC Reforçado
com Tecido de Poliéster 2424

Espessura 2,10mm (DIN EN 22.286)

Peso de 2.380g/m² (DIN EN 22.286)

Adesão de 5Kg / 5cm (DIN 53.357/A)

Resistência a Ruptura (DIN 53.354)
Longitudinal 980Kg / 5cm
Transversal 900Kg / 5cm

Alongamento a Ruptura (DIN 53.354)
Transversal / Longitudinal de 18%

Resistência ao Rasgo (DIN 53.363)
Longitudinal 85Kg
Transversal 80Kg

